

# Bourns在车用电池管理系统之解决方案

2018.03

**BOURNS®**

# 大纲

- 电池历史
- 电池管理系统
- 电动车之电池管理系统架构
- Bourns在 车用电池管理系统之解决方案
  - 电源滤波及电压转换
  - 高电压的过流保护及电池均衡
  - 车用通讯控制介面
  - **负载突降保护**
  - 电流检测
  - 大电流电池MOSFET
- 电动车之车充及电源转换
- Q & A

# 电池历史

- 1800年伏打发明了电池
- 随着电池的演進。现在最流行的是锂离子电池由於
  - 高能量密度
  - 高开路电压 (3.7V~4.2V)
  - 高输出功率
  - 没有记忆效应
  - 充电/放电快

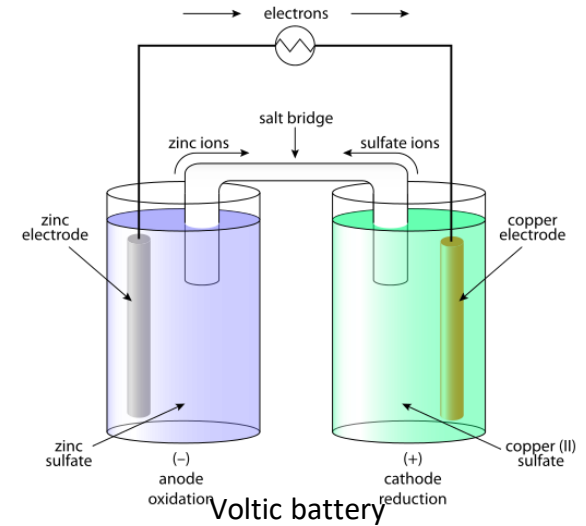

Li-ion battery



Li-ion polymer battery

然而锂离子不是稳定的材料，所以我们需要多重保护方法来保护它

# 电池管理系统(BMS)

---

- 什么是BMS:
  - 电池监测，在充电和放电过程中对关键的运行参数进行检查
- 为什么需要BMS
  - 电池状态监控 - 电压/电流/温度
  - 电芯电量平衡
  - 外部模组通讯

# 电动车之电池管理系统架构

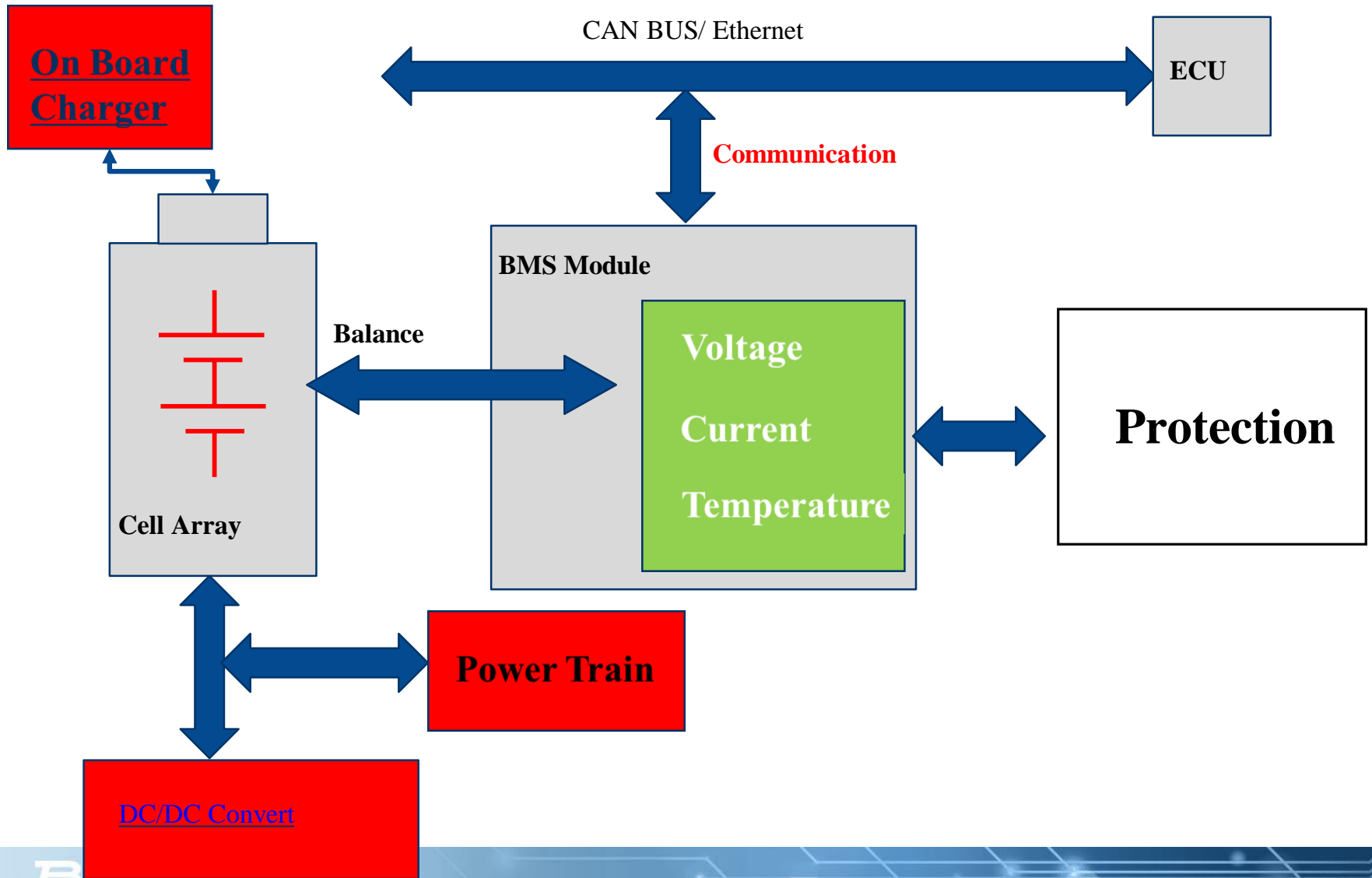

# Bourns在车用电池管理系统之解决方案



高压TVS二极管

2 CDDFN-T5.0LC/TBU-DB/CRE



过电流电压保护

3 SRF4530A CDSOT23-T24CAN-Q



SPI菊花链介面隔离

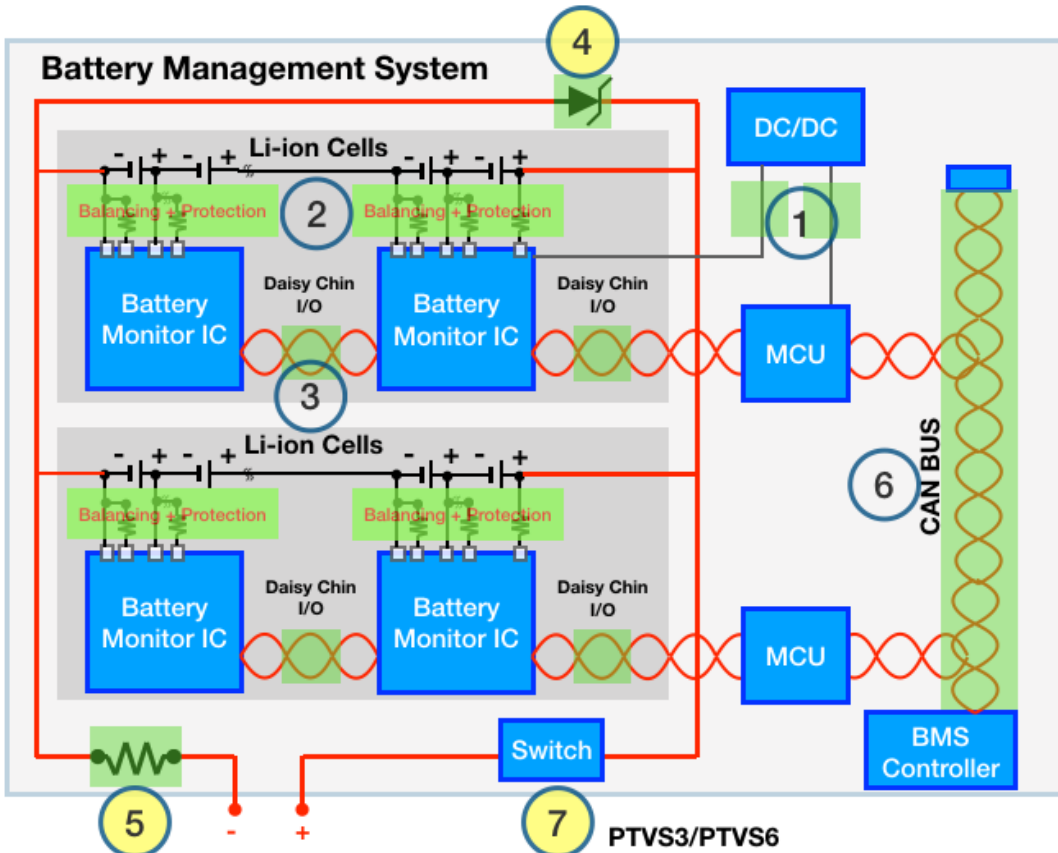

1 SM91070AEL SM91068L



DC / DC隔离 芯片直流电源

6 SRF4530A CDSOT23-T24CAN-Q MF



EMI滤波器, 浪涌和过流保护

5 PTVS3/PTVS6

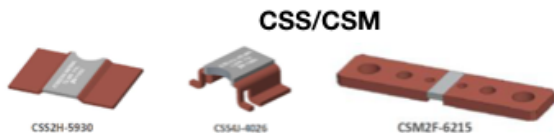

高电流电池 MOSFET保护

CSS/CSM



高电流检测 精密金属分流器

# 电源滤波及电压转换

7100, 7300, 7400, 7500, 8100

PM3700, SRF0703, SRF1260, SRF1280

- Power conversion application
- High perm. toroid or UU core, close magnetic loop construction to maximize CM impedance
- Available Models: 9
- Inductance Range: 0.2 – 50mH
- Rated Current Range: 0.27 – 20A
- Frequency Range: 10K – 50MHz
- Size Range:  
0.75-1.7" (L) x 0.43-0.9" (W) x 0.6-1.2" (H)



# 电池被动均衡设计

- 被动均衡设计 (Passive Balancing Design)

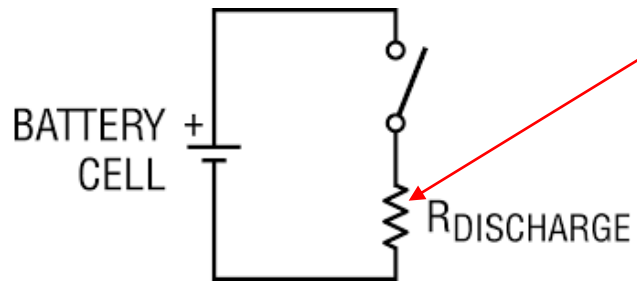
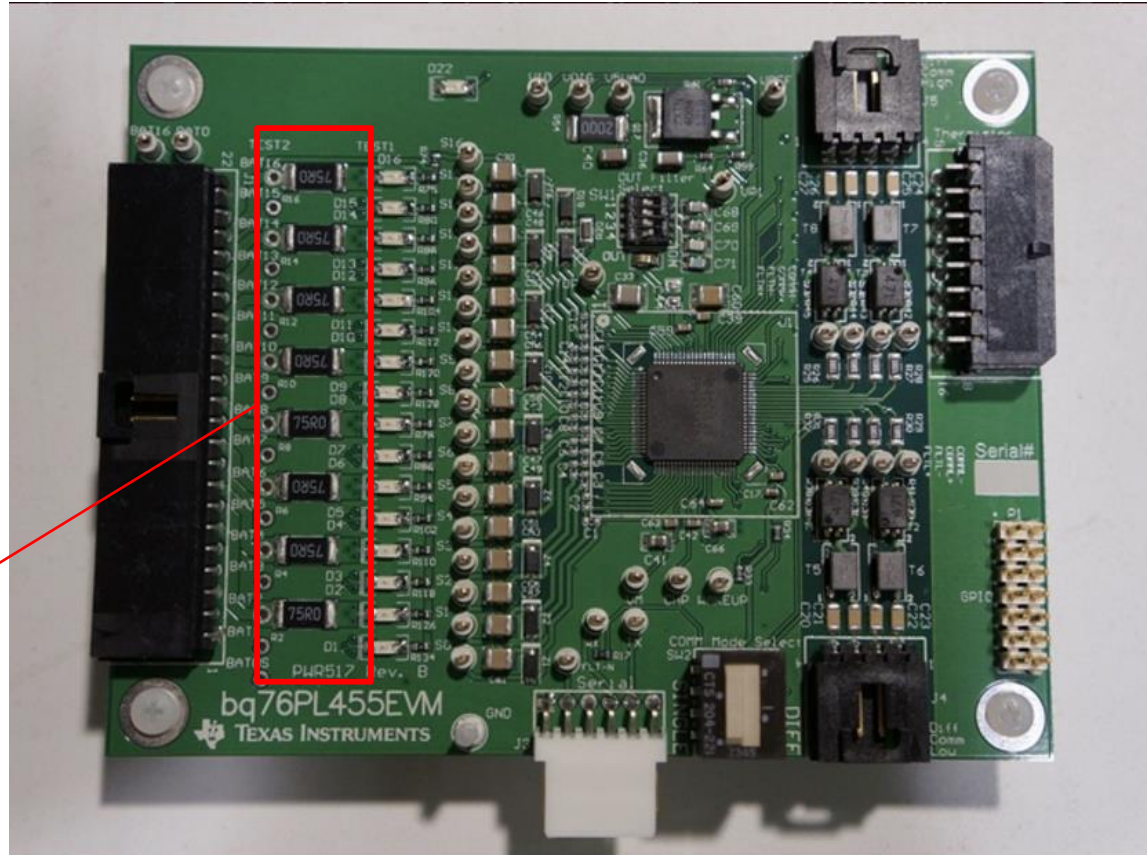



# 高电压的过流保护

## Transient Blocking Unit

- Ultra Fast Resettable Protector
- High Voltage Rating ( 550V)
- Ultra Fast Reaction (micro seconds)
- Trip Current Max 150mA
- Resistance 12  $\Omega$
- Reset Voltage 7V
- Applications
  - Loose Busbar
  - Mis-wiring of Cell Tap Wires

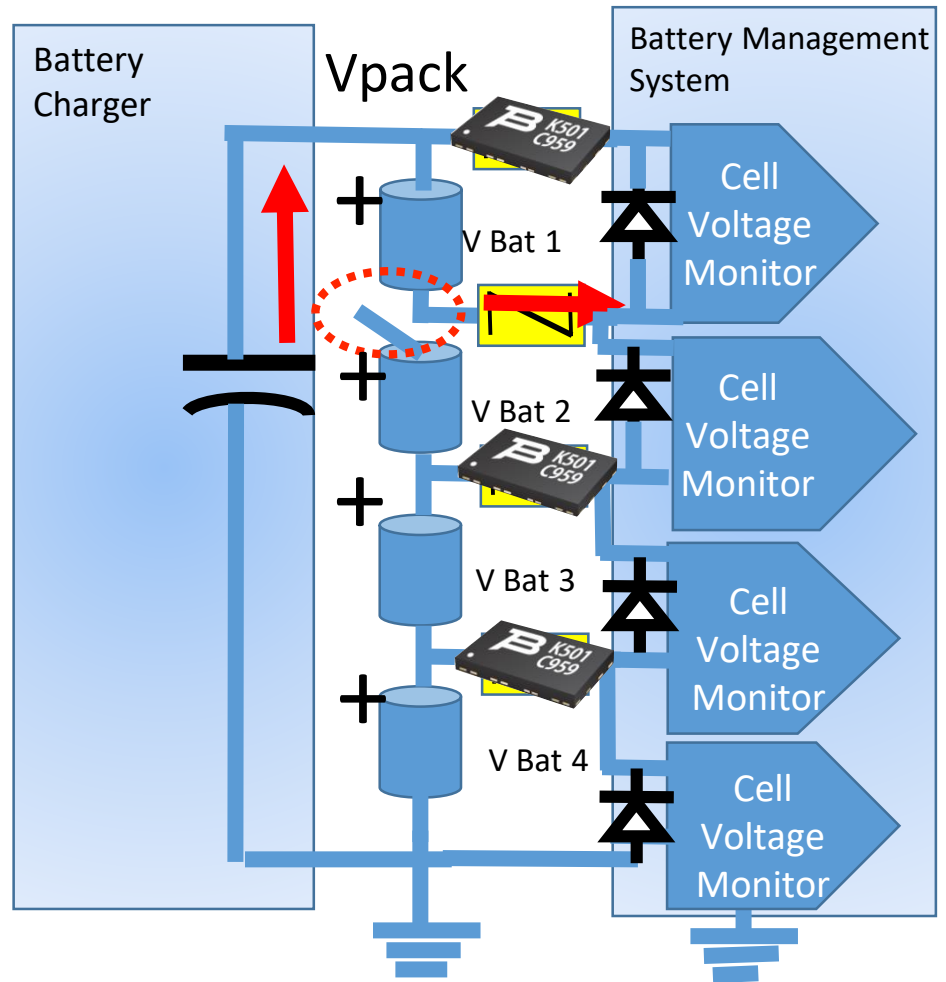

# 车用通讯控制介面



<a href="#"><u>CAN - ISO 11898</u></a>	The CAN bus (Controller Area Network) was introduced to enable the networking of a large number of ECUs. It permits high data rates in diagnostics and flash programming.
<a href="#"><u>LIN</u></a>	LIN bus (Local Interconnected Network) enables the inexpensive integration of sensors and actuators in vehicle networks. It creates small subnets.
<a href="#"><u>Flex Ray</u></a>	Flex Ray was invented at the beginning of this century to be able to implement an appropriate bus system for security-critical applications. It enables deterministic time responses and is designed to be redundant.
<a href="#"><u>MOST</u></a>	MOST (Media Oriented System Transport) was introduced at the beginning of this century to simplify the integration of infotainment ECUs into the vehicle thanks to its special communication mechanisms and high data rates.
<a href="#"><u>Ethernet</u></a>	With Ethernet, a standard that has been used successfully for years now in networking is currently being introduced to automotive electronics. In addition to inexpensive components, a major advantage is the extremely high bandwidth - both in onboard communication and in flash programming.
<a href="#"><u>SPI</u></a>	Serial Peripheral Protocol (SPI) was first introduced with the first microcontroller deriving from the same architecture as the popular Motorola 68000 microprocessor, announced in 1979. SPI defined the external microcontroller bus, used to connect the microcontroller peripherals with 4 wires.

# CAN (控制器局域网) 总线

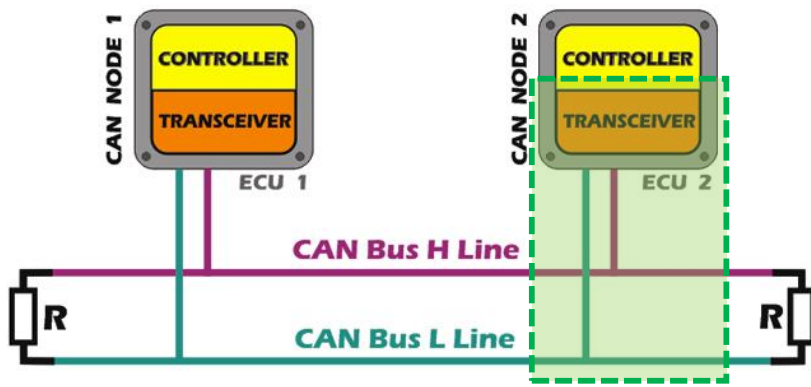

## Basic CAN BUS Transceiver Circuit

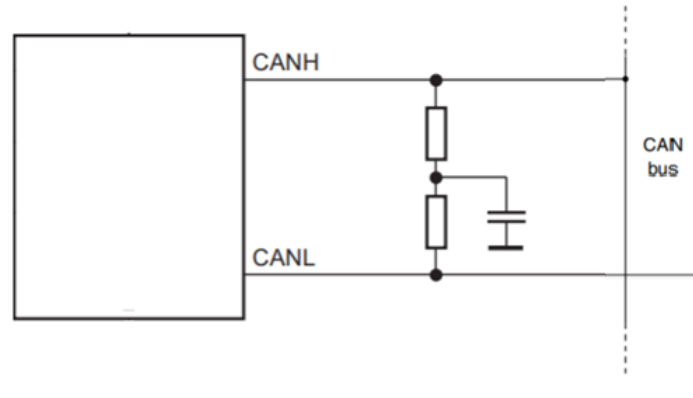

## Enhanced CAN BUS Transceiver Circuit

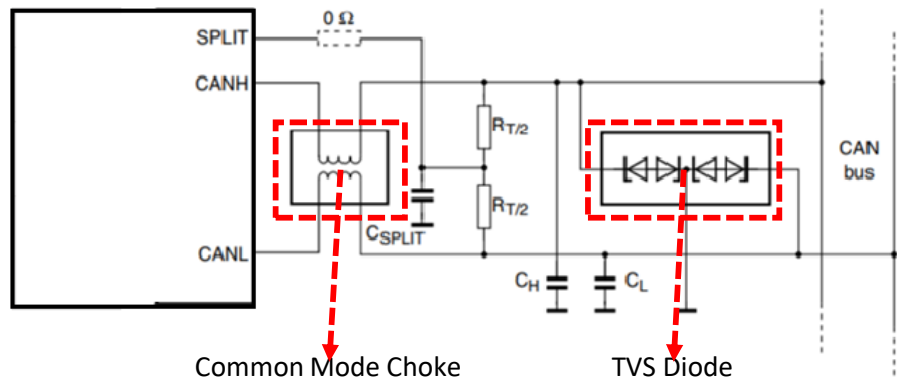

Common Mode Choke : To reduce noise.

TVS Diode : To offer ESD protection

# CAN总线参考设计

## Texas Instruments Reference Design

Link : <http://www.ti.com/lit/ug/tidub36b/tidub36b.pdf>

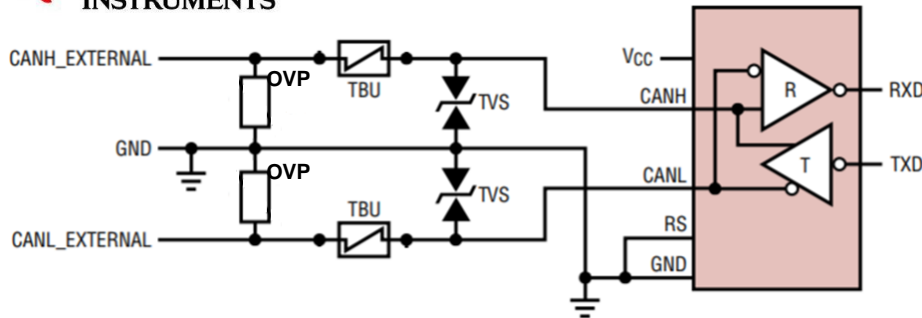

PROTECTION SCHEME	IEC ESD (KV)	IEC EFT (KV)	IEC Surge (KV)
TVS	± 30 Contact	± 4	± 2
	± 30 Air		
TVS/TBU/MOV	± 30 Contact	± 4	± 6
	± 30 Air		
TVS/TBU/TISP	± 30 Contact	± 4	± 6
	± 30 Air		
TVS/TBU/GDT	± 30 Contact	± 4	± 6
	± 30 Air		

TVS CDSOT23-SM712  
 TBU TBU-CA085-200-WH  
 MOV MOV-10D201K  
 TISP TISP4249M3BJR-S  
 GDT 2031-42T-SM-RPLF

## Linear Technology Reference Design

Link : <http://cds.linear.com/docs/en/datasheet/2875f.pdf>

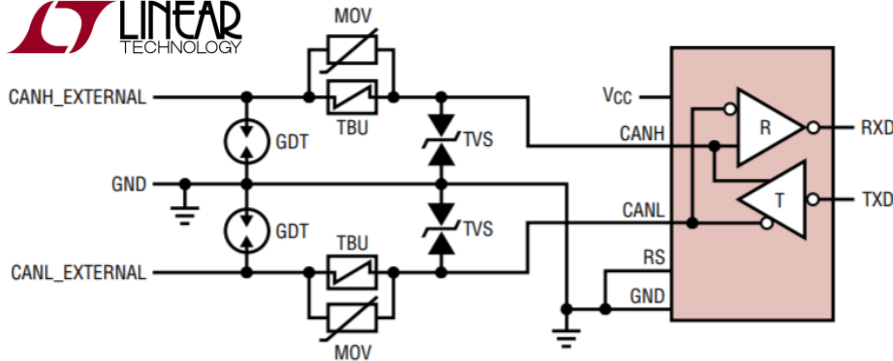

PROTECTION SCHEME	IEC ESD (KV)	IEC EFT (KV)	IEC Surge (KV)
TVS/TBU/MOV/GDT	± 15 Contact	± 5	± 5
	± 30 Air		

TVS CDSOD323-T36SC  
 TBU TBU-CA050-300-WH  
 MOV MOV-7D201K  
 GDT 2031-15T-SM-RPLF

# CAN总线保护

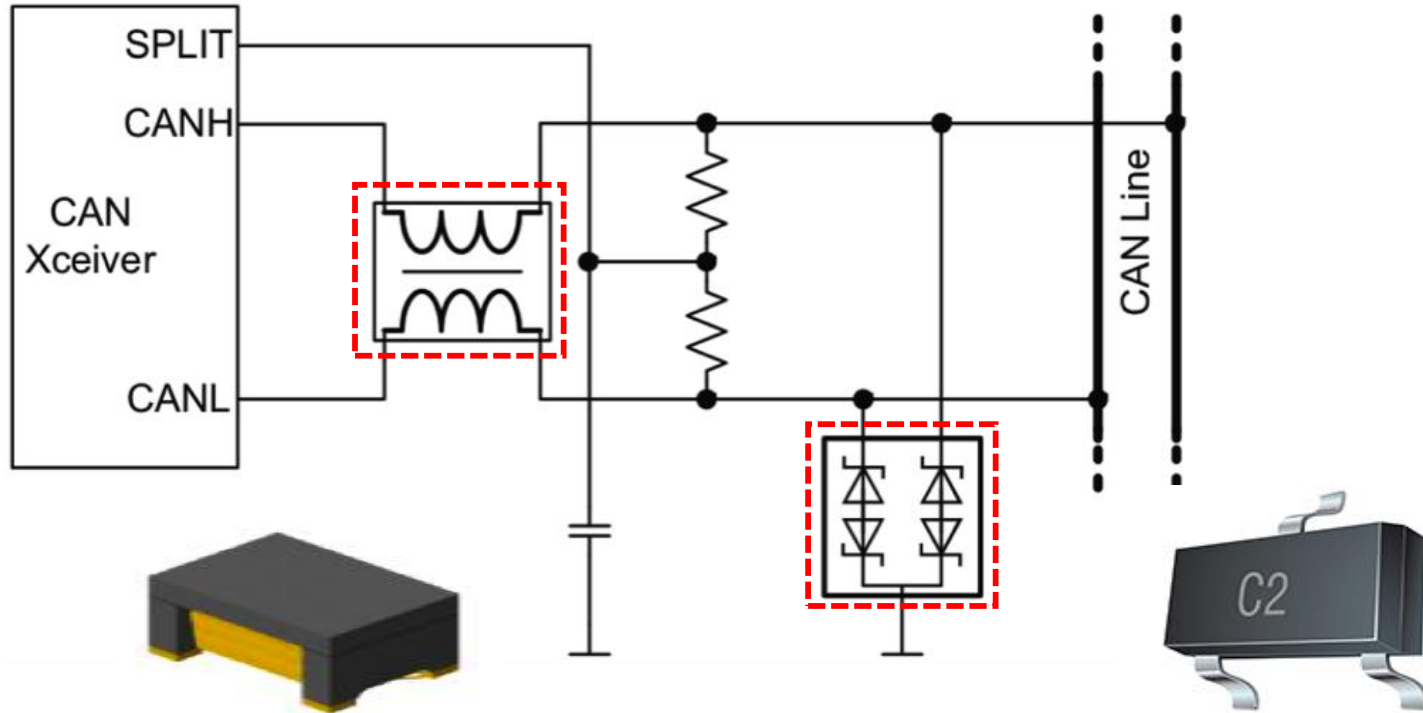

## Common Mode Choke ( CMC )

- [SRF4530A-510Y](#) : Size 4530
- [SRF3225TA-510Y](#) : Size 3225

## TVS Diode

- [CDSOT23-T24CAN](#) :

# 汽车以太网

## Basic Ethernet Transceiver Circuit

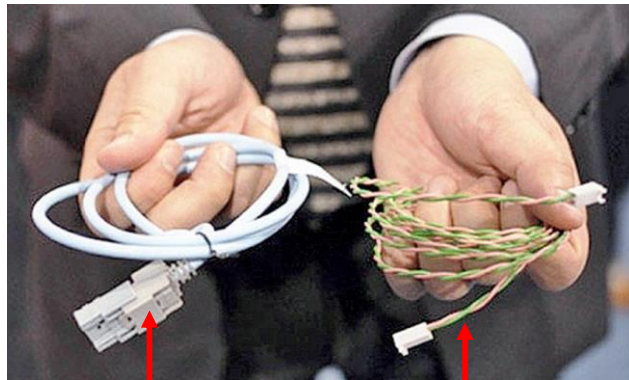
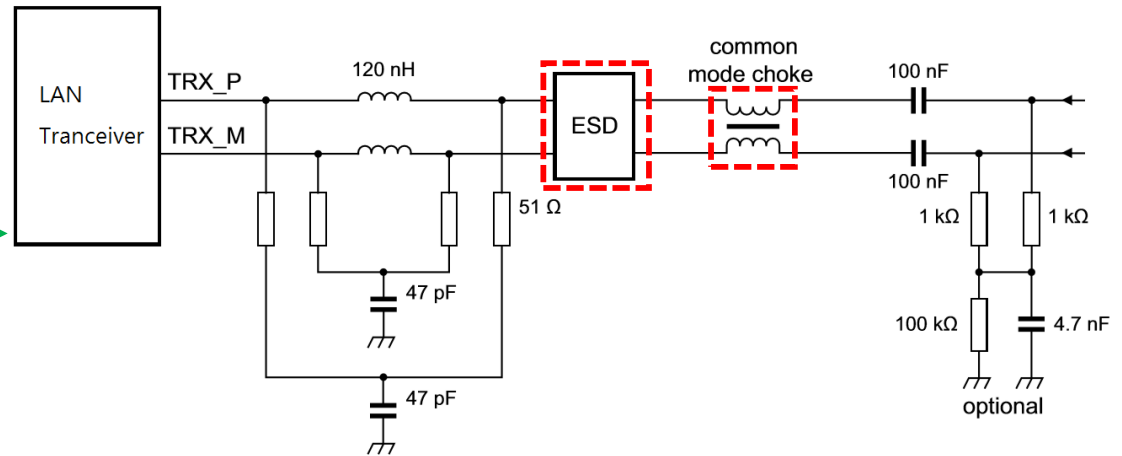
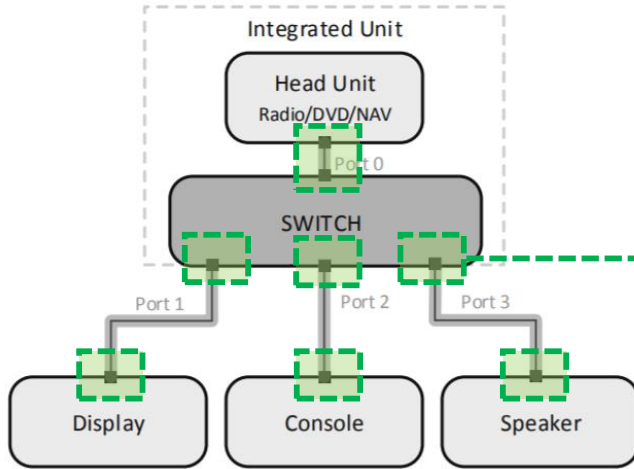

Normal Ethernet Cable

Automotive Ethernet Cable

## 100 Mbps symmetrical operation using standard Ethernet PHY components

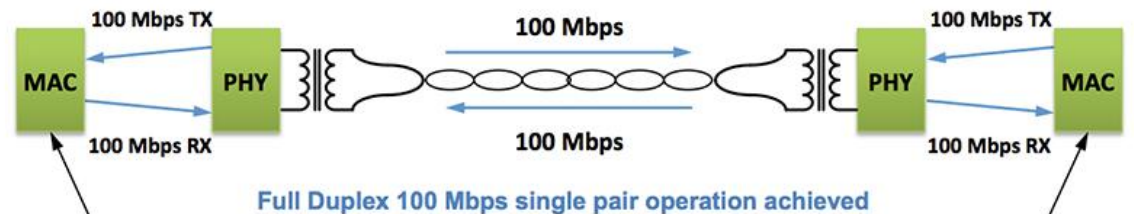

Only change is to wire-side,  
MAC-side remains the same

Standard IEEE 802.3  
100Mbps MAC  
Interface

Standard IEEE 802.3  
100Mbps MAC  
Interface

# 汽车以太网保护

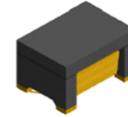

Common Mode Choke ( CMC )

- [SRF4530AB-201Y](#) : Size 4530
- [SRF3225TAB-210Y](#) : Size 3225

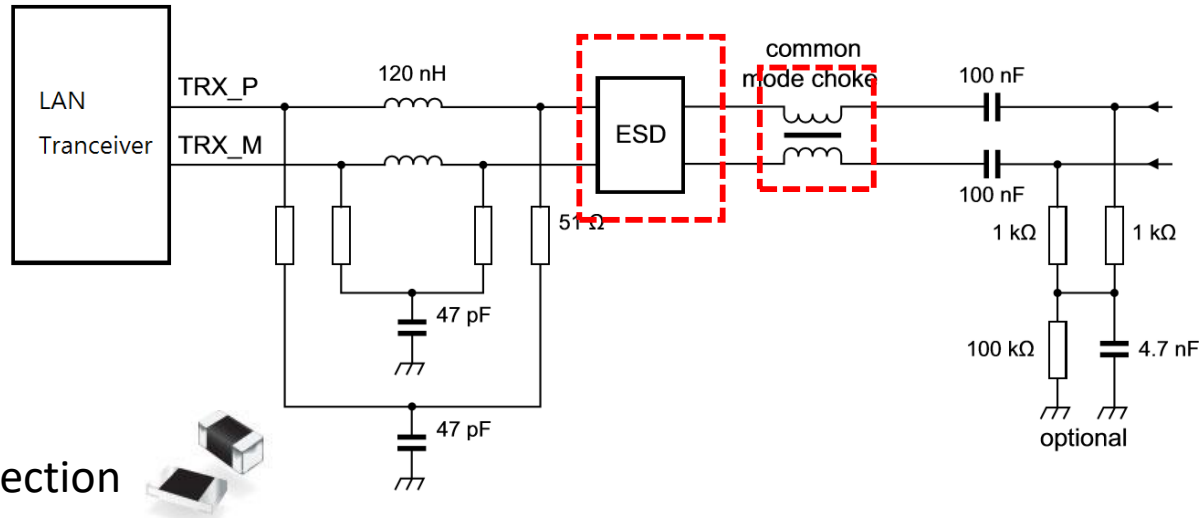

## ESD Protection



Ultra Low Capacitance and Clamping Voltage make airgap technology suitable for ESD Protection of CAN Interfaces

Model	Technology	Capacitance	Voltage	Typical Clamping Voltage	IEC61000-4-4
CGA0402/0603MLC	Airgap	0.05-0.2pF	5,12,24 V	30V	Level 4

**The high surge capability of the multilayered technology makes them more suitable for applications having to withstand not just ESD but surges as per ISO7637-2**

Model	Technology	Capacitance	Voltage	Clamping Voltage	Surge Capability (8/20μs)
CGA0603/0805/1206MLA	Multilayer	12-840pF	16-56V	Minimum 48V	Max 200A

# 串行外设接口保护

## MECHANICAL SPECIFICATIONS

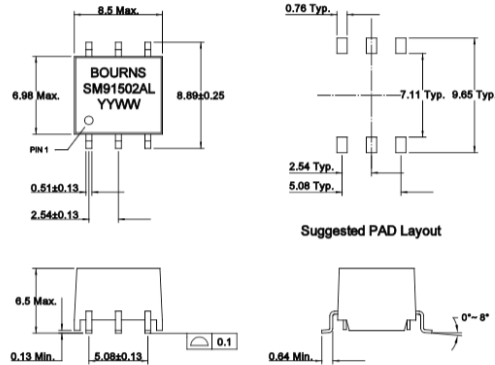

單路

## SCHEMATIC AND CONSTRUCTION DRAWING

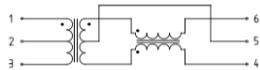

## MECHANICAL SPECIFICATIONS

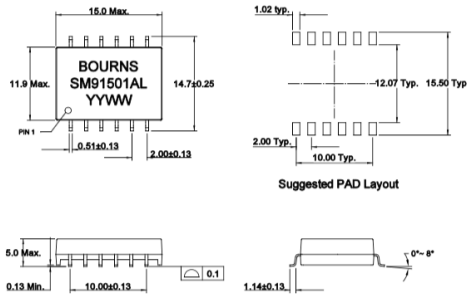

双路

## SCHEMATIC AND CONSTRUCTION DRAWING

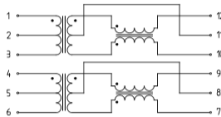

## ELECTRICAL SPECIFICATION @25°C:

1. OCL (100kHz/0.1V) : 150uH Min, 450uH Max. (-40°C~+125°C)
2. Leakage inductance (100kHz/0.1V): 0.5uH Max.
3. DCR: Transformer side : 0.45  $\Omega$  Max.;  
CM choke side: 0.85  $\Omega$  Max.
4. Turns Ratio : 1 : 1  $\pm$  2%
5. Insertion Loss:  
4 MHz: -0.25dB Max.
6. Return Loss ( Z out= 100  $\Omega$  ):  
4 MHz: -22dB Min.
7. Cross Talk (Between each channel):  
4MHz: -50dB Min.
8. Common Mode Rejection Ratio :  
1~10MHz: -35dB Min.  
10~1000MHz: -20dB Min.
9. HI-POT (1mA, 60S): 4300VDC or 3100VAC.
10. Design construction: Functional insulation  
Working voltage:1600V for 15 years.
11. Creepage distance: >10mm.

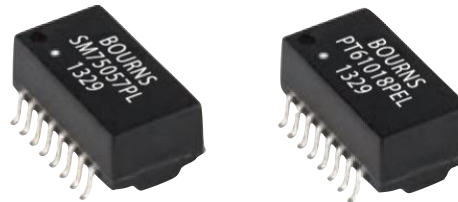











# 可恢复保险丝 - Multifuse® PPTC

## 贴片型

Series	Product Photo	Type	Footprint	Vmax	Hold Current I hold – (Amps)
<a href="#">MF-MSMF</a>		Surface Mount	1812	6 Vdc - 60 Vdc	0.10 - 2.60
<a href="#">MF-SMDF</a>			2018	10 Vdc - 60 Vdc	0.55 - 2.60
<a href="#">MF-LSMF</a>			2920	6 Vdc - 33 Vdc	1.85 - 3.00
<a href="#">MF-SM</a>			Refer to Data Sheet	6 Vdc - 60 Vdc	0.3 - 1.1 & 2.6/1.25 - 3.0
<a href="#">MF-SMHT</a>			Refer to Data Sheet	16 Vdc	1.36 - 1.60
<a href="#">MF-SM/250</a>			Refer to Data Sheet	60 Vdc/250 Vac	0.13
<a href="#">MF-SM/250V</a>			Refer to Data Sheet	60 Vdc/250 Vac	0.13
<a href="#">MF-SD/250</a>			Refer to Data Sheet	60 Vdc/250 Vac	0.13

# 可恢复保险丝 - Multifuse® PPTC

## 插件式

Series	Product Photo	Type	Footprint	Vmax	Hold Current I hold – (Amps)
<a href="#">MF-R</a>		Radial Leaded Through Hole	Refer to Data Sheet	16 Vdc - 60 Vdc	0.05 - 11.0
<a href="#">MF-R/600</a>				60 Vdc/600 Vac	0.15 - 0.16
<a href="#">MF-R/90</a>				90 Vdc/90 Vac	0.55 - 0.75
<a href="#">MF-RG</a>				16 Vdc	3.0 - 11.0
<a href="#">MF-RHT</a>				16 Vdc - 30 Vdc	0.5 - 13.0
<a href="#">MF-RM</a>				240 Vdc/265 Vac	0.05 - 0.55
<a href="#">MF-RX</a>				60 Vdc	1.1 - 3.75
<a href="#">MF-RX/250</a>				60 Vdc/250 Vac	0.12 - 0.18
<a href="#">MF-RX/72</a>				72 Vdc	0.2 - 3.75

# 负载突降保护

## 负载突降

- High surge ( up to 400V ) is caused by
  - Abnormal disconnection between generator and charging battery
  - Car starting
- ISO defines automotive load dump test

Parameter	Type of system		Minimum test requirements
	UA = 12 V	UA = 24 V	
Us (V)	79 to 101	151 to 202	10 pulses at intervals of 1 min.
Ri (Ohm)	0.5 to 4	1 to 8	
td (ms)	40 to 400	100 to 350	
tr (ms)	10 / +0 / -5	10 / +0 / -5	

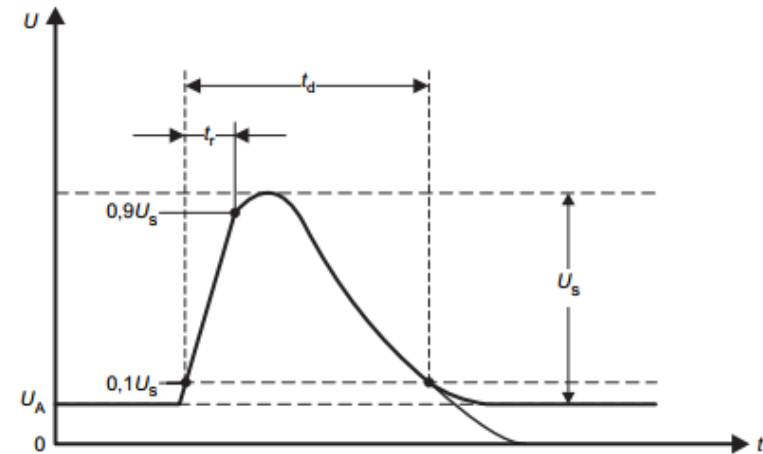
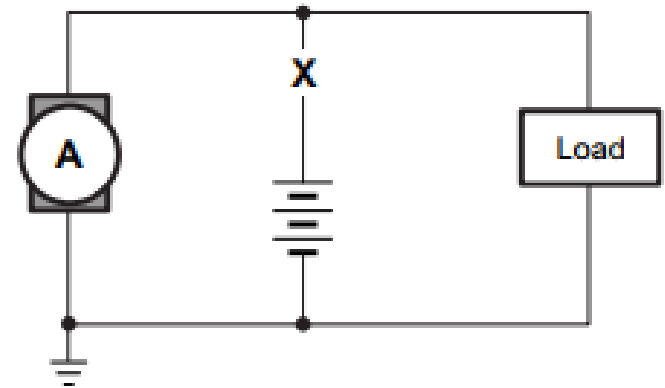

ProtectSolution for load dump issue → TVS Diode

# LED照明负载突降保护

## Load Dump Protection

- Solution → TVS Diode
- Protection in front of ECU circuit

TVS Diode for load dump

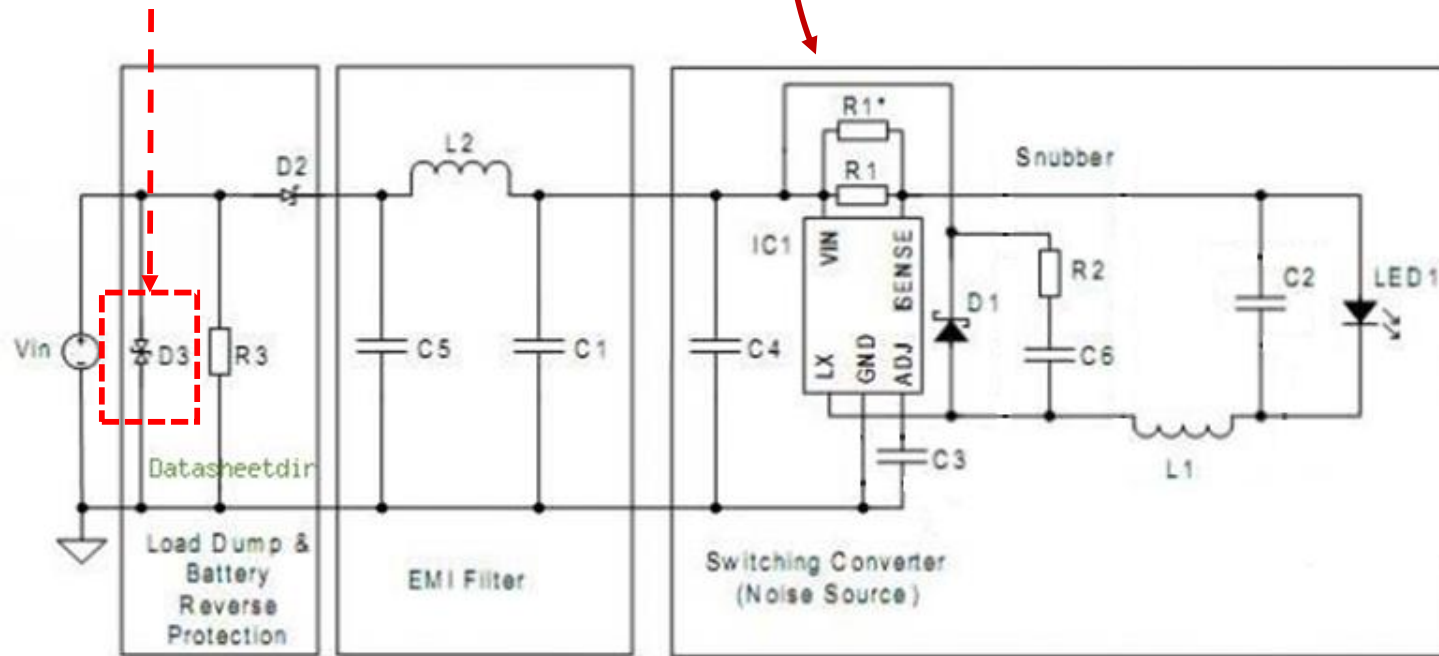
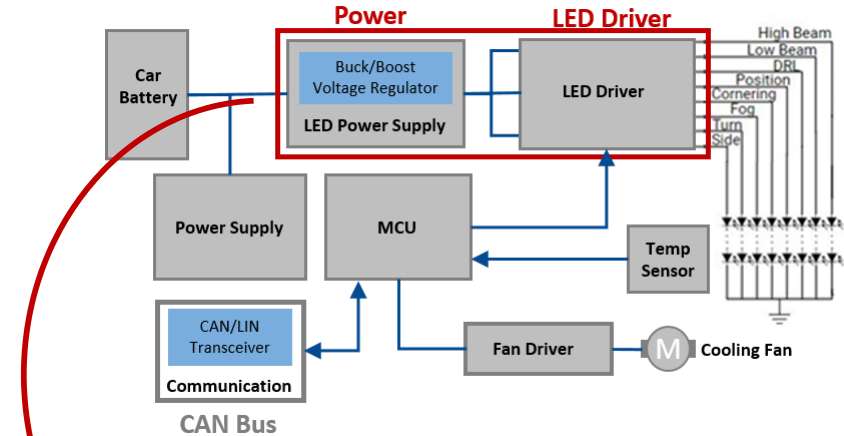

# 负载突降保护

## 负载突降保护主要特点

ISO-16750-2 defines automotive load dump test. This replaces ISO 7632-2 with a more stringent test regime.

Key factors to define with customers



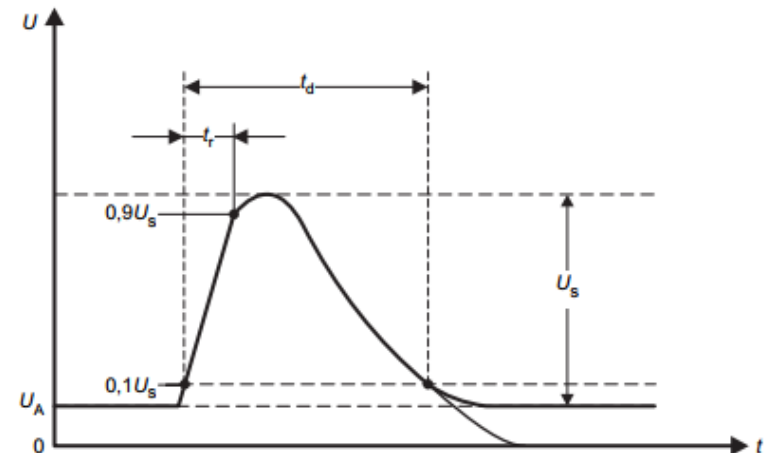

- Type of system – 12V or 24V (24V systems require a much larger diode)
- $R_i$  ( $\Omega$ ) – Specification defines a very wide range, without agreement use upper limit!
- $T_d$  (ms) - Specification defines a very wide range, without agreement use upper limit!

Note : There will have further standard for 48V power system.

Parameter	Type of system		Minimum test requirements
	UA = 12 V	UA = 24 V	
$U_s$ (V)	79 to 101	151 to 202	10 pulses at intervals of 1 min.
$R_i$ (Ohm)	0.5 to 4	1 to 8	
$t_d$ (ms)	40 to 400	100 to 350	
$t_r$ (ms)	10 / +0 / -5	10 / +0 / -5	

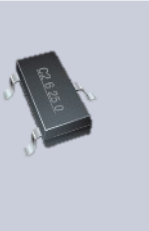

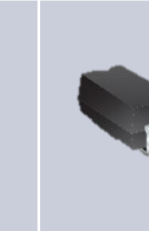
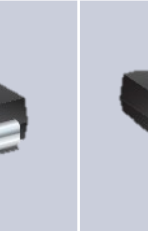
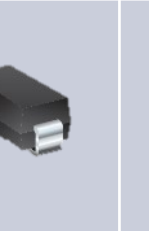
# 车用TVS二极管

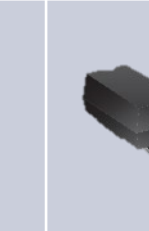
	CDSOT23-T24CAN-Q	CDSOD323-TxxC-DSL-Q	SMAJ-Q	SMBJ-Q	SMCJ-Q	SMLJ-Q	5.0SMDJ-Q	SM8SF33CA-Q
Package								
Package Type	SOT-23	SOD323	DO-214AC (SMA)	DO-214AA (SMB)	DO-214AB (SMC)	DO-214AB (SMC)	DO-214AB (SMC)	0.41" x 0.32"
Peak Pulse Power (Watt) (10/1000 μs)	-	-	400	600	1500	3000	5000	7000
Peak Pulse Current (A) (10/1000 μs)	8 (8/20μs)	11 / 6 (8/20μs)	20.1 ~ 4.3	30.2 ~ 6.5	75.4 ~ 16.1	150.6 ~ 32	252 ~ 72.1	132
Stand-Off Voltage (V)	24	12 / 24	12 ~ 58	12 ~ 58	12 ~ 58	12 ~ 58	12 ~ 43	33
Breakdown Voltage (V)	26.2	13.3 / 26.7	13.3 ~ 64.4	13.3 ~ 64.4	13.3 ~ 64.4	13.3 ~ 64.4	13.3 ~ 47.8	36.7

# SM8SF33CA-Q

## Features

- Standoff Voltage: 33 volts to support 24VDC. Additional voltages available upon request
- Power Dissipation: 7000 watts (10/1000 us)
- Maximum Peak Pulse Current: 132 A (10/1000  $\mu$ s)
- Meets ISO7637-2 / ISO16750-2 surge specification





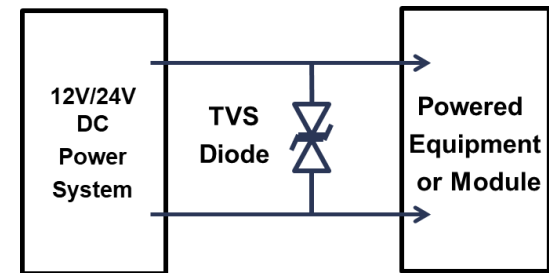
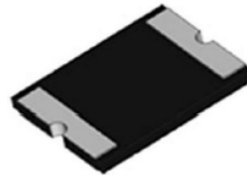

## Applications

- Load dump protection - DC power supply protection against voltage transients induced by inductive load switching, lighting, etc.



Cross Reference				
Vishay	$V_{RWM}$ (Typ)	$I_{PP}$ (10/1000 $\mu$ s)	Power Peak Pulse	Package
SM5S33AHE3_A/I	33V	68A	3600W (3.6kW)	 DO-218AB
SM6S33AHE3_A/I	33V	86A	4600W (4.6kW)	
SM8S33AHE3_A/I	33V	124A	6600W (6.6kW)	

# 电流检测电阻

Resistor Family	Image	Max Current	Voltage Drop at Maximum Current
CST0612		44.7A	22.3mV
CRE2512		55.0A	50.0mV
CSS2H-2512		140A	42.4mV
CSS2H-3920		245A	49mV
CSS2H-5930		126.5A	63mV
CSS4J-4026R		100A	50mV

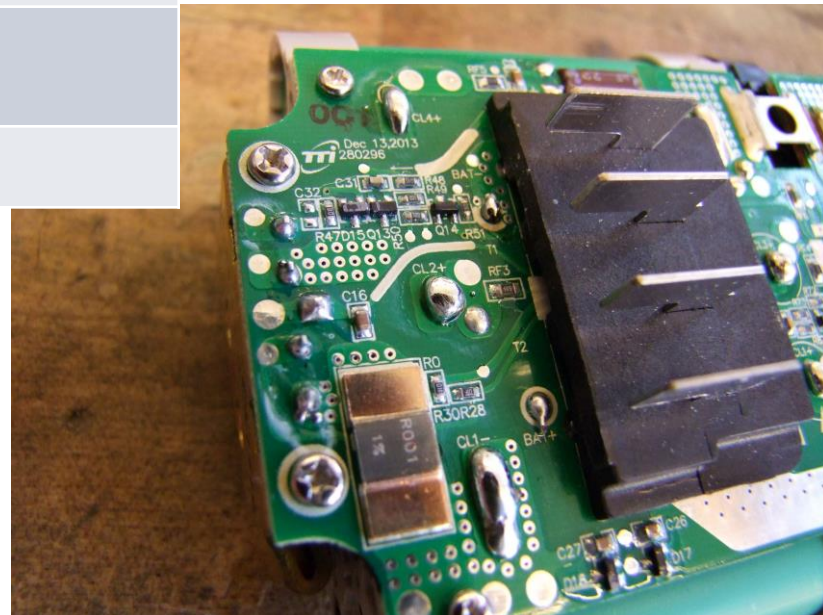



# Shunts Resistor– Portfolio and new launches

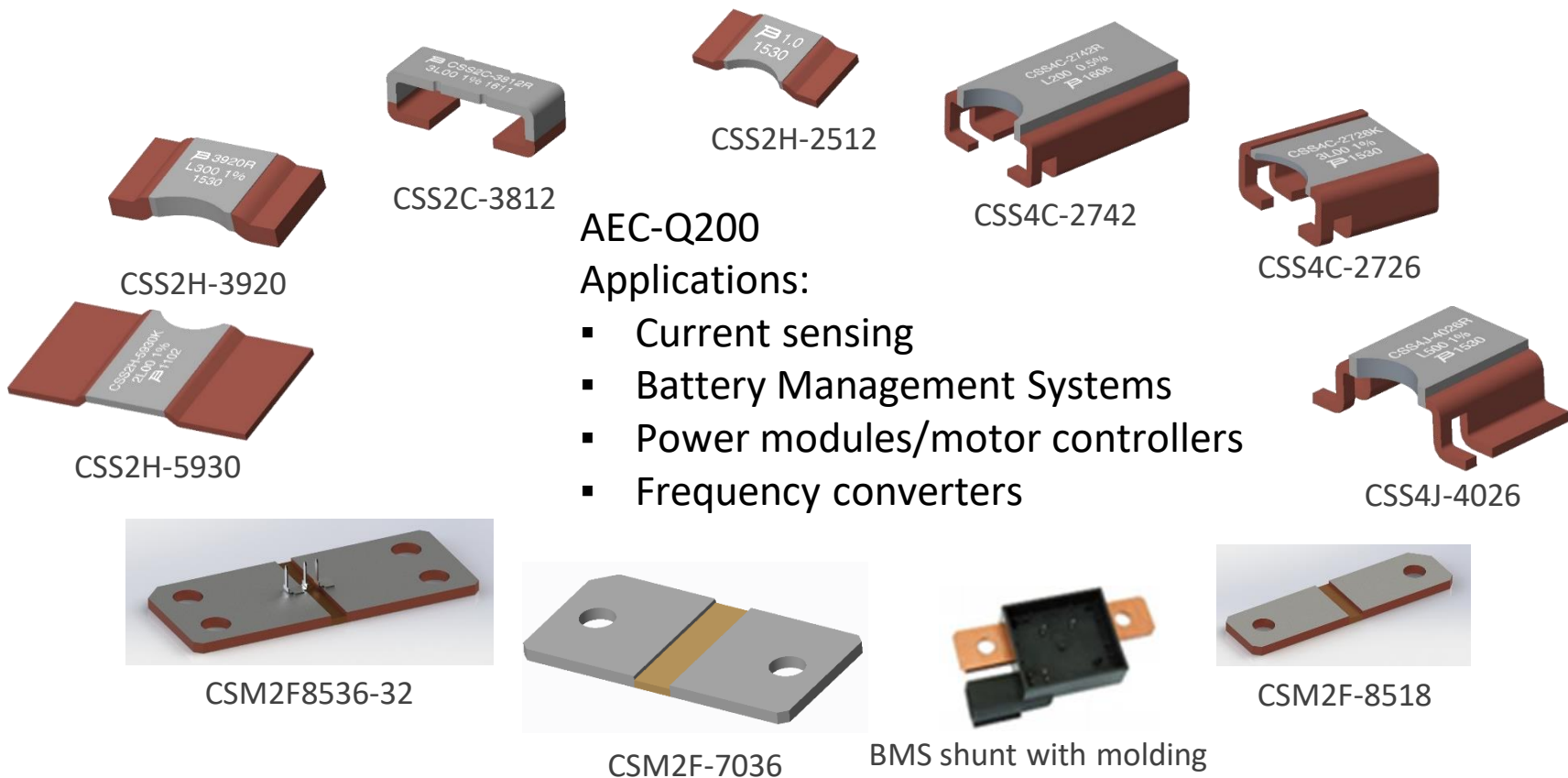

AEC-Q200

Applications:

- Current sensing
- Battery Management Systems
- Power modules/motor controllers
- Frequency converters

- Added pulse curves
- Added inductance in electrical characteristics
- Change trimming from one side to both sides
- Added total height

# Shunts Resistor – Portfolio and new launches



**Features**

- Up to 36 W permanent power
- Continuous current load up to 1000 A
- High pulse power rating
- Maximum fastening torque: 10 Nm
- Tinned terminals
- Customized versions available
- AEC-Q200 and RoHS\* compliant

**Applications**

- Battery management systems
- Current sensing for hybrid & electric vehicles
- Current sensing in bus bars
- Current sensing in welding equipment
- Frequency converters

**Model CSM2F-8518 Series Current Sense Resistor**

**Electrical Characteristics**

Characteristic	Model CSM2F-8518 Series
Resistance Range / Power Rating @ 70 °C	50 MicroOhms / 36 Watts
Operating Temperature Range	-40 °C to +170 °C
TCR on Test Pulse	±0.50 PPM/°C
TCR Resistance Alloy***	< ±0.50 PPM/°C
Thermal EMF (µV/K)	< 0.25 for 50 MicroOhms
Resistance Tolerance	±0.5 %

\*\*\* Terminal temperature  
\*\* For full TCR range, refer to TCR curves.



**Features**

- Up to 50 W permanent power
- Continuous current load up to 1000 A
- High pulse power rating
- Maximum fastening torque: 10 Nm
- Tinned terminals
- Customized versions available
- AEC-Q200 and RoHS\* compliant

**Applications**

- Battery management systems
- Current sensing for hybrid & electric vehicles
- Current sensing in bus bars
- Current sensing in welding equipment
- Frequency converters

**Model CSM2F-7036 Series Current Sense Resistor**

**Electrical Characteristics**

Characteristic	Model CSM2F-7036 Series
Resistance Range / Power Rating @ 70 °C	50 MicroOhms / 50 Watts
Operating Temperature Range	-40 °C to +170 °C
TCR on Test Pulse	±0.50 PPM/°C
TCR Resistance Alloy***	< ±0.50 PPM/°C
Thermal EMF (µV/K)	< 0.25 for 50 MicroOhms
Resistance Tolerance	±0.5 %

\*\*\* Terminal temperature  
\*\* For full TCR range, refer to TCR curves.

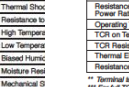

**Features**

- Up to 36 W permanent power
- Continuous current load up to 1000 A
- High pulse power rating
- Maximum fastening torque: 10 Nm
- Tinned terminals
- Customized versions available
- AEC-Q200 and RoHS\* compliant

**Applications**

- Battery management systems
- Current sensing for hybrid & electric vehicles
- Current sensing in bus bars
- Current sensing in welding equipment
- Frequency converters

**Model CSM2F-6918 Series Current Sense Resistor**

**Electrical Characteristics**

Characteristic	Model CSM2F-6918 Series
Resistance Range / Power Rating @ 70 °C	50 MicroOhms / 36 Watts
Operating Temperature Range	-40 °C to +170 °C
TCR on Test Pulse	±0.50 PPM/°C
TCR Resistance Alloy***	< ±0.50 PPM/°C
Thermal EMF (µV/K)	< 0.25 for 50 MicroOhms
Resistance Tolerance	±0.5 %

\*\*\* Terminal temperature  
\*\* For full TCR range, refer to TCR curves.

	CSS	CSM
<b>Construction</b>	EB welded Mn/Cu alloy	
<b>Low Resistance</b>	0,1 to 5 mOhms	0,05 to 5 mOhms
<b>High power rating</b>	1 to 15 W	1 to 50 W
<b>Low TCR</b>	±75 to 150 ppm/°C	±150 ppm/°C

3 standard sizes:

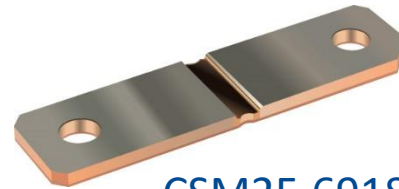

CSM2F-6918

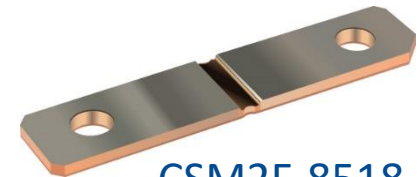

CSM2F-8518

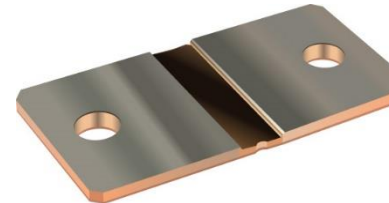

CSM2F-7036

\*RoHS Directive 2002/95/EC, Jan. 27, 2002 including annex and RoHS Recast 2011/654/EU June 8, 2011.  
Specifications are subject to change without notice.  
The above characteristics and parameters in this data sheet can and do vary in different applications and actual device performance may vary over time.  
Users should verify actual device performance in their specific applications.

# 大电流电池MOSFET 保护

The parasitic inductance of power cables is sufficient to develop a high back-EMF and damage high-cost MOSFETS in high-capacity, high-current battery systems.

MIL-STD-1275E defines such a disconnect test. (Commercial equivalent exists, e.g. Volvo requirements on 48V battery disconnect switch. Battery disconnect safety devices are becoming standard, these disconnects high currents in less than one ms after an electric signal is triggered such as following a crash)

Such battery systems are found in electric-vehicles and energy storage systems, for e.g.

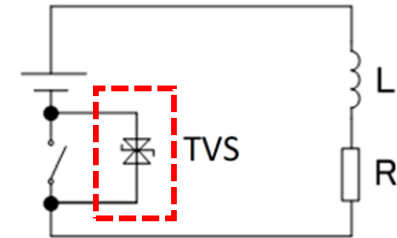
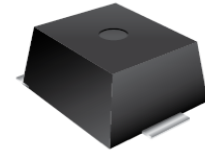

Overcoated  
for 15kA



Overcoated for  
3~10kA

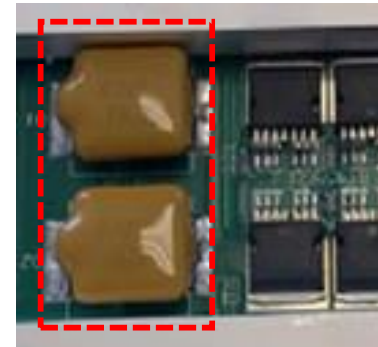

# 大电流电池MOSFET 保护

Bourns PTVS devices are currently rated to 8/20 $\mu$ s current impulse.

It is critical to define with customer,

- L – Line inductance
- Peak Current – Line voltage,  $V_{\text{clamp}}$  required, Load resistance
- Above would determine the impulse current waveform (decay time)

Bourns PTVS devices are easily customized for

- By determining the customer impulse current waveform, we can simulate, design and characterize appropriate products
- $V_{\text{RWM}}$  – Working voltage is achieved through changing the number of chips stacked.
- $I_{\text{pp}}$  – Current rating is achieved through the surface area of the chips used.

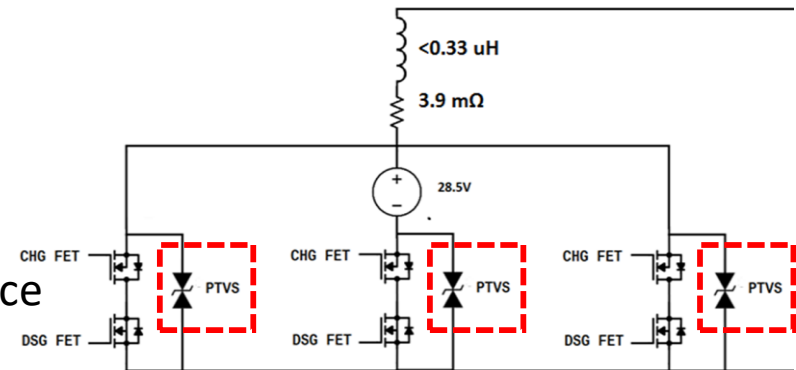
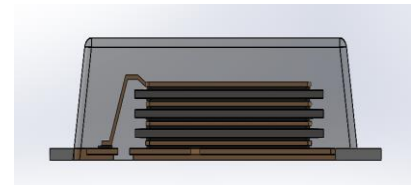
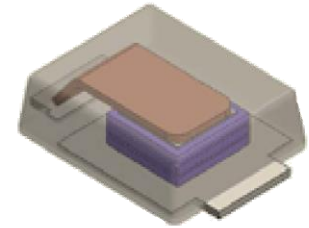
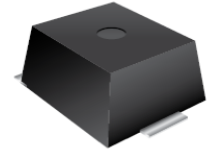

# Bourns Power TVS Diode PTVS3-M



## PTVS3-xxxC-M Series High Current TVS Diodes

### Features

- 3 kA, 8/20  $\mu$ s surge capability
- Low clamping voltage under surge
- Bidirectional TVS
- Surface mount package
- Excellent overtemperature performance

### Applications

- High power DC bus protection
- MOSFET protection



### Absolute Maximum Ratings (@ $T_A = 25^\circ\text{C}$ Unless Otherwise Noted)

Rating		Symbol	Value	Unit
Repetitive Standoff Voltage	PTVS3-066C-M PTVS3-076C-M	$V_{WM}$	66 76	V
Peak Current Rating per 8/20 $\mu$ s IEC 61000-4-5		$I_{PPM}$	3	kA
Operating Junction Temperature Range		$T_J$	-55 to +125	$^\circ\text{C}$
Storage Temperature Range		$T_S$	-55 to +150	$^\circ\text{C}$

### Electrical Characteristics (@ $T_A = 25^\circ\text{C}$ Unless Otherwise Noted)

Parameter	Test Conditions		Min.	Typ.	Max.	Unit
$I_D$ Standby Current	$V_D = V_{WM}$				10	$\mu\text{A}$
$V_{(BR)}$ Breakdown Voltage	$I_{BR} = 10\text{ mA}$	PTVS3-066C-M PTVS3-076C-M	72 85	76 90	80 95	V
$V_C$ Clamping Voltage	$I_{PP} = 3\text{ kA}$	PTVS3-066C-M PTVS3-076C-M			120 135	V
$V_{(BR)}$ Temperature Coefficient				0.1		$\%/^\circ\text{C}$
C Capacitance	F = 10 kHz, $V_d = 1\text{ Vrms}$	PTVS3-066C-M PTVS3-076C-M		2.0 1.7		nF

More information, please visit Bourns Web Site : <http://www.bourns.com/products/diodes/power-tvs-diodes>

# 电动车-车充

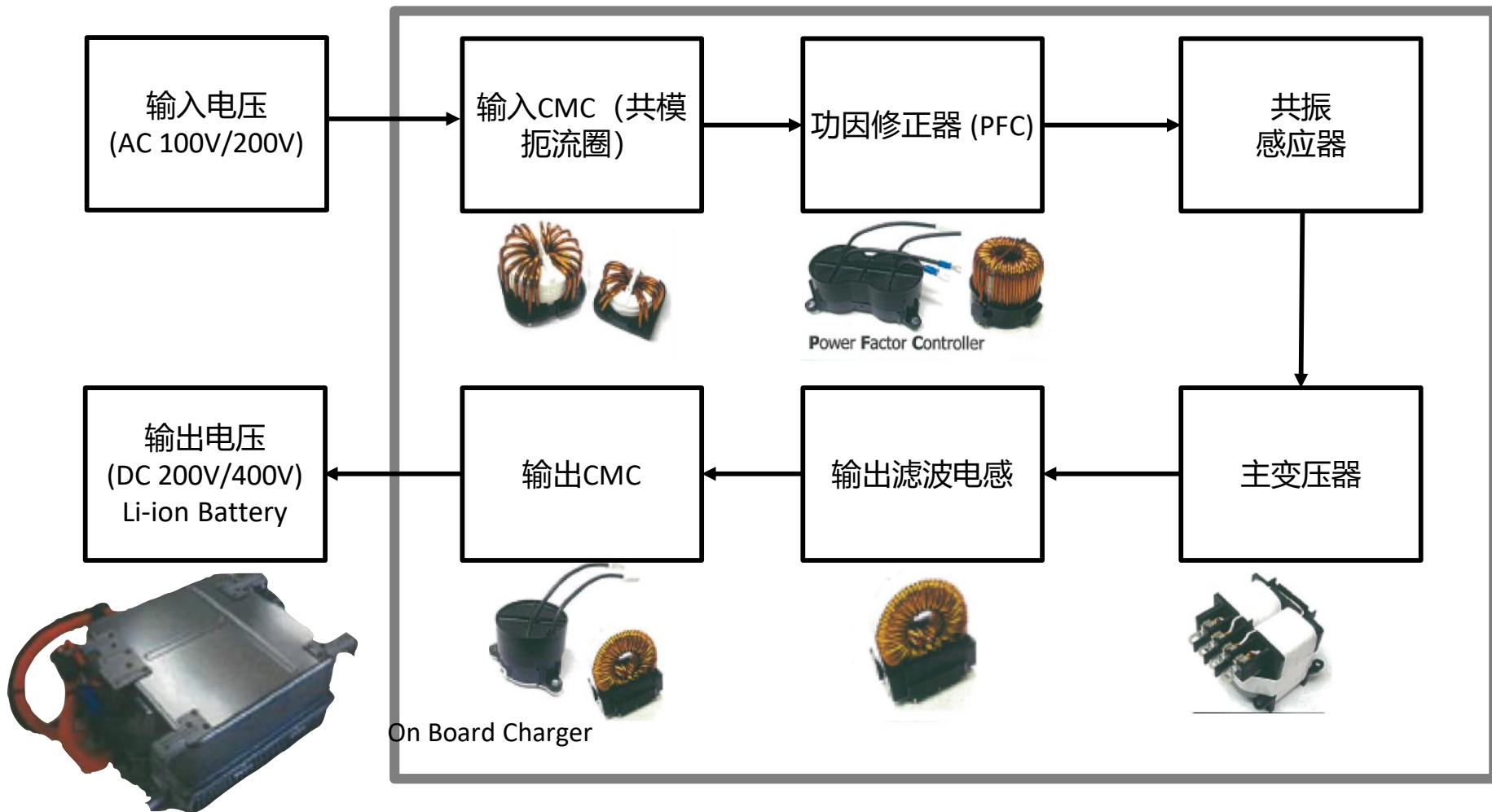

# 电动车-电源转换

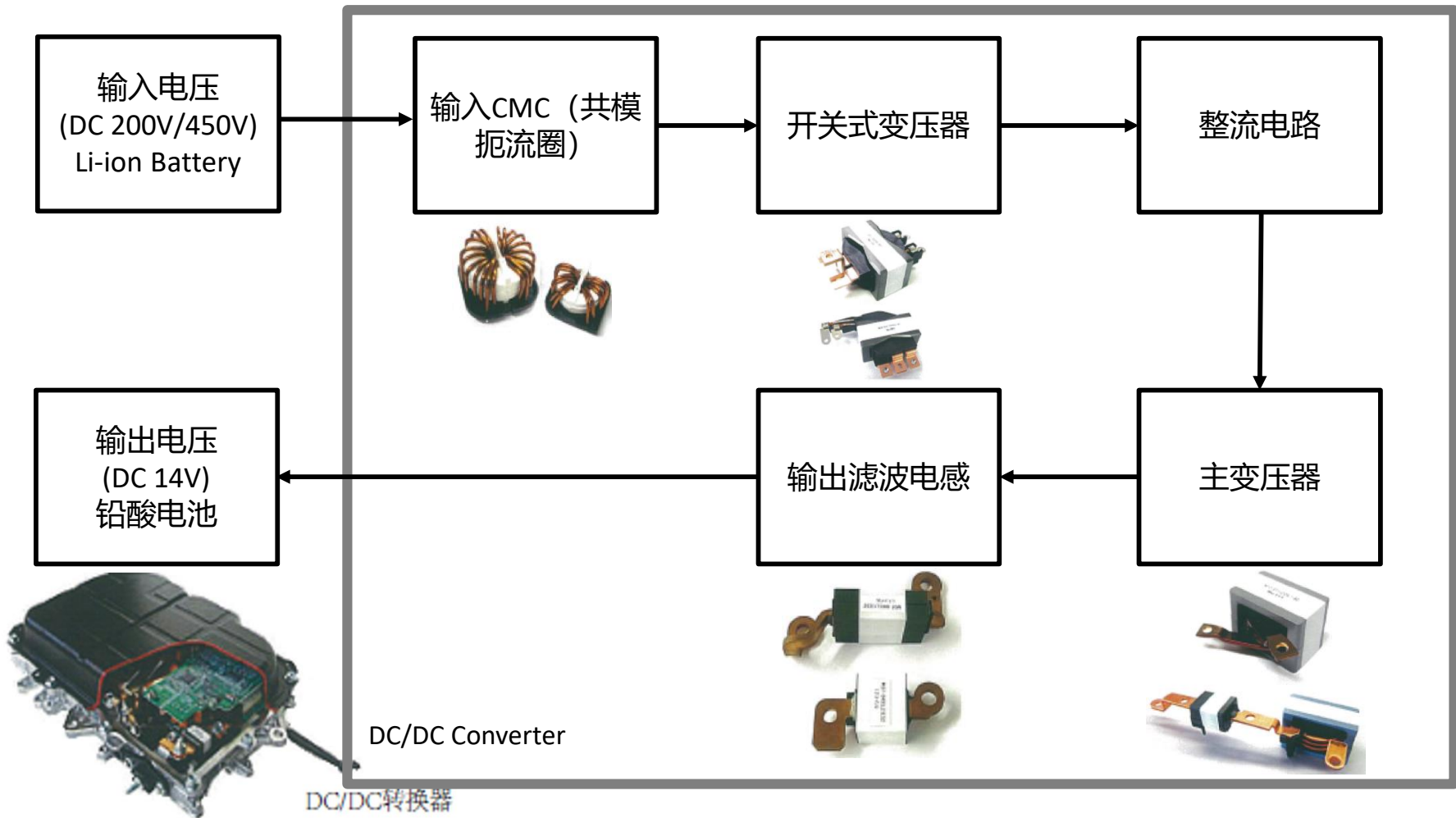

# 代理商信息

**世健国际贸易（上海）有限公司**

[www.excelpoint.com.cn](http://www.excelpoint.com.cn)

**Nanjing Office**

**Angus Zhao 138 517 46806 [angus.zhao@excelpoint.com.cn](mailto:angus.zhao@excelpoint.com.cn)**

**Shenzhen Office**

**Sunny Bian 135 103 42980 [sunny.bian@excelpoint.com.cn](mailto:sunny.bian@excelpoint.com.cn)**



Thank you!

**BOURNS®**